

Datasheet

SATADOM-QH 2IE series

- iSLC technology
- Smart Power Pin 7 VCC Design
- iSMART disk health monitoring
- Intelligent error recovery system
- Excellent data transfer speed
- Write protection security
- Zero moving parts
- Highly Reliable Industrial Design



Introduction

Qualified by Intel, Innodisk's SATADOM-QH 2IE is the world's smallest SATA SSD, featuring built-in Pin 7 VCC technology that enhances the functionality of various embedded applications. With its cable-less and rugged design, the QH 2IE provides high reliability and allows for easy integration with other systems. The QH 2IE is also lightweight and available in capacities from 8GB up to 64GB.

InnoDisk SATADOM-QH 2IE adopts iSLC technology, which is designed to outdo the endurance, performance and reliability of MLC-based solutions. Through the use of flash management algorithms, iSLC improves SSD endurance up to 30,000 times, increasing lifespans up to 10 times longer than MLC-based solutions.

SATADOM-QH

2IE series

Contact us for more information about the SATADOM-QH 2IE

Innodisk is a service-driven provider of industrial embedded flash and DRAM storage products and technologies, with a focus on the cloud computing, industrial/embedded, and aerospace and defense industries.

Drawing

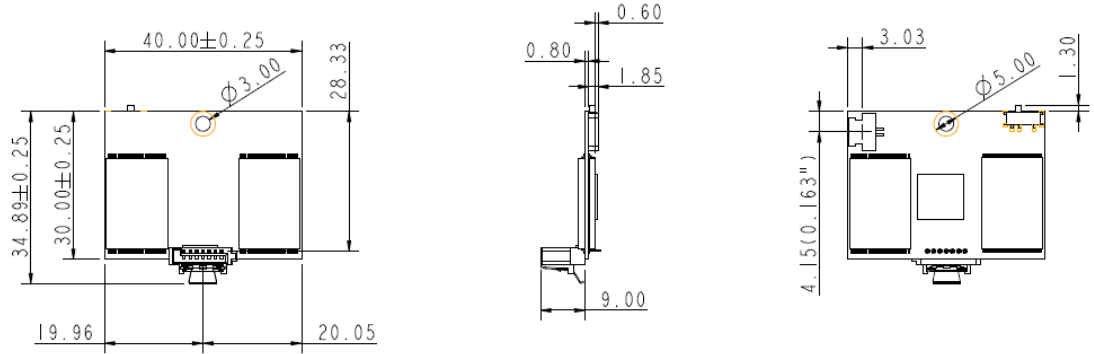

Specifications

| | |
|-------------------------------|---|
| Interface | SATA II |
| Flash Type | iSLC |
| P/E Cycle limit | 30,000 |
| Capacity | 8GB~64GB |
| Max. Channels | 4 |
| Sequential R/W (MB/sec, max.) | 125 / 120 |
| Max. Power Consumption | 1.57 W (5V x 314 mA) |
| Thermal Sensor | √ |
| H/W Write Protect | √ |
| i-Socket | - |
| Pin7 Power | Optional |
| ATA Security | Supported |
| S.M.A.R.T. | Supported |
| Dimension (WxLxH) | 40.0 X 30.0 X 10.8 mm |
| Environment | Vibration: 20G @7~2000Hz Shock: 1500G @ 0.5ms Storage Temperature: -55°C ~ +95°C MTBF: 3 million hours |

Headquarters (Taiwan)

9F., No.100, Sec. 1, Xintai 5th Rd.,
Xizhi Dist., New Taipei City,
Taiwan (R.O.C.)
Tel: +886-2-26963000
Email: sales@innodisk.com

Branch Offices:

USA
usasales@innodisk.com
+1-510-770-9421
Europe
eusales@innodisk.com
+31-040-282-2382
Japan
jpsales@innodisk.com
+81-3-6661-9846
China
sales_cn@innodisk.com
+86-755-21673689
www.innodisk.com

© 2012 Innodisk Corporation.
All right reserved. Specifications
are subject to change without
prior notice.

20130110

Ordering Information

| Operation Temp. | 8GB | 16GB | 32GB | 64GB |
|---------------------------------|--------------------|--------------------|--------------------|--------------------|
| Standard Grade (0°C ~ +70°C) | DHSMH-08GJ301C1QNF | DHSMH-16GJ301C1QNF | DHSMH-32GJ301C1QNF | DHSMH-64GJ301C1QNF |

innodisk

www.innodisk.com